

HEAT KING

HK 150 MOBILE GLYCOL HEATING SYSTEM

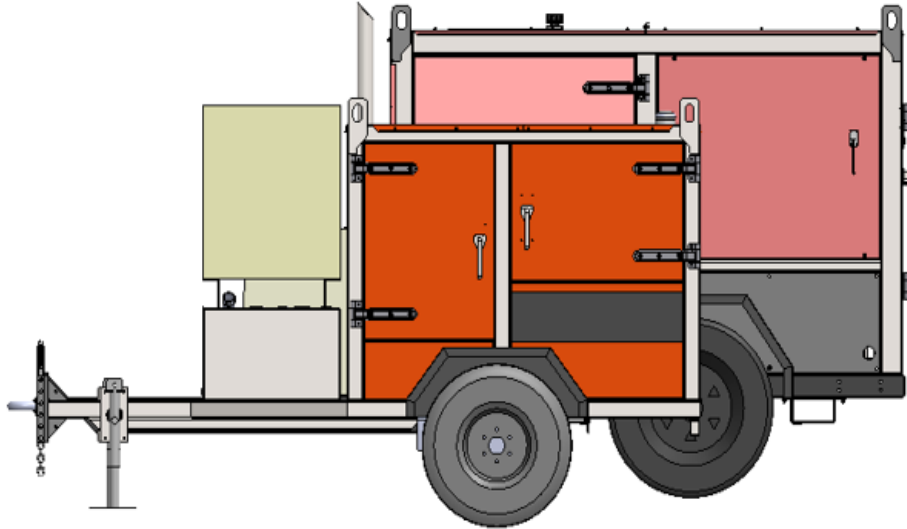

NEW COMPACT DESIGN



FEATURES

- 2-700FT HOSES
- THAW UP TO 2,800 FT²
- CURE UP TO 5,600 FT²
- TEMPORARY HEAT UP TO 6,200 FT²
- NEW COMPACT DESIGN (124"X72"X70")
- 50+ HRS RUN TIME
- LIFTING HOOKS & FORKLIFT POCKETS (STANDARD)
- BI-DIRECTIONAL POWERED REEL WITH FREEWHEEL FEATURE
- ON BOARD AIR COMPRESSOR

DOUBLE LOOP TECHNOLOGY

By using shorter hoses, more fluid, and higher efficiency pumps with increased flow, the Heat King provides more consistent temperature to the field for better concrete curing and ground thawing results.

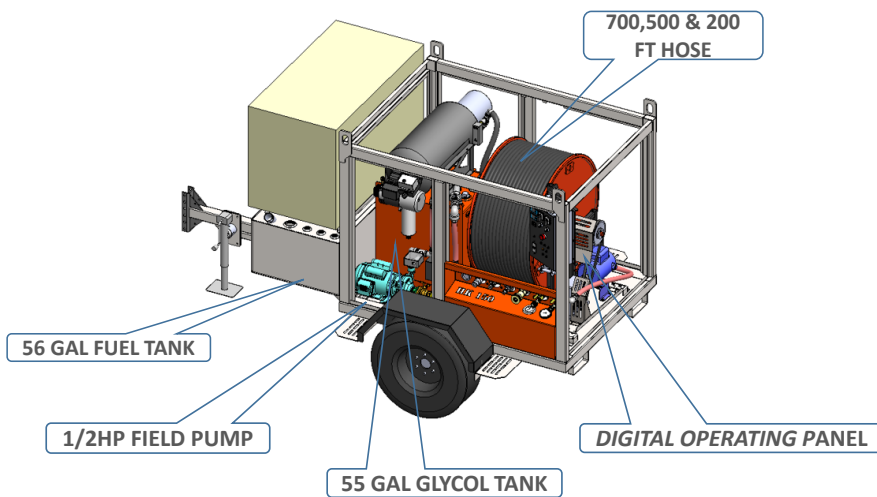
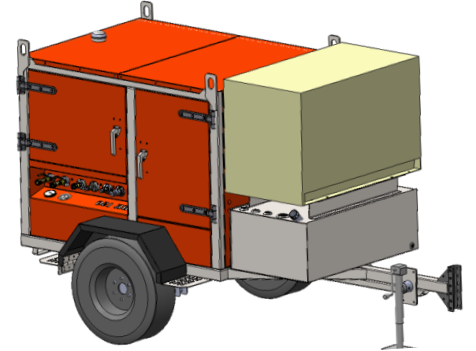
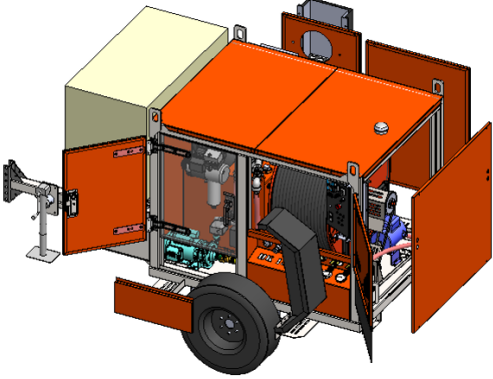

HK150 SPECIFICATIONS

• Hose	1-700 ft, 1-500ft, 1-200ft (5/8" Hose)	• Interior Lights	Standard for ease of night operation
• Hose	Unspool with one person	• Mud Tray	Added under the reel to catch mud debris
• Supply Manifold	2 - 1/2" quick connect & 1 - 1" quick connect	• Heater Capacity Diesel	150,000 BTU/H Heating Fuel Input
• Return Manifold	2 - 1/2" quick connect & 1 - 1" quick connect	• Glycol Tank	55 US GAL
• Ground Thawing Capacity	2,800 ft ²	• Electrical Requirements	1 - 120V AC 20A Circuits
• Concrete Curing Capacity	5,600 ft ²	• Generator (Optional)	1 - 7,000W
• Temporary Heating Capacity	6,200 ft ² (Varies with R-Value)	• Axle	1 - 4400lbs Leaf Springs, Electric Brakes
• Field Pump	1/2 Hp Centrifugal	• Hitch	2 5/16" Ball (Pintle also available)
• Circulating Pump	1/2 Hp Centrifugal	• Dimensions	124"x72"x70"
• Fuel Tank	56 US GAL	• Weight (Fuel Empty/Full)	3,450 / 4,300 lbs
• Run Time	50+ Hours		
• Larger Wheels	Higher capacity & better towing		
• Flo Indicator	Ensures proper operation		